

CB-B型大排量齿轮泵

概述

CB-B型斜齿大排量泵是液压系统中的动力元件。该泵采用高精度齿轮，高强度铸铁壳体，使其具有结构简单、排量大、效率高、噪音低、使用可靠等优点，其广泛应用于油田、矿山机械、农业机械等液压系统中。



订购码

CB - B 2.5 X
 齿轮泵 公称压力 2.5MPa 公称流量 X: 逆时针旋转
 空白: 顺时针旋转

性能参数

产品型号	排量	额定压力	额定转速 r/min	驱动功率 kw	容积效率	重量 kg
CB-B160	160	2.5	1450	11.37	>90	30
CB-B200	200			14.22	>90	34
CB-B250	250			17.76	>90	36
CB-B315	315			22.39	>90	38.5
CB-B350	350			24.88	>90	40
CB-B400	400			28.43	>90	42.5
CB-B500	500			31.98	>90	42
CB-B550	550			35.54	>90	43
CB-B600	600			40	>90	44
CB-B700	700			49.75	>90	57
CB-B1000	1000			37	>90	
CB-B1500	1500			55	>90	

外形尺寸

CB-B160~400斜齿大排量型号规格

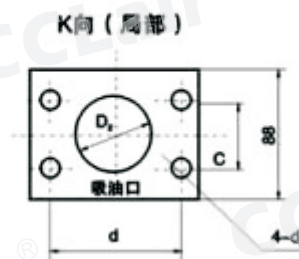
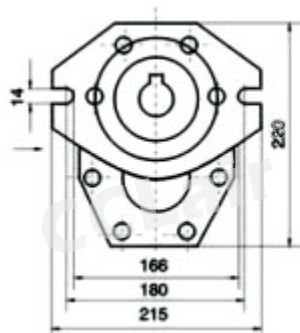
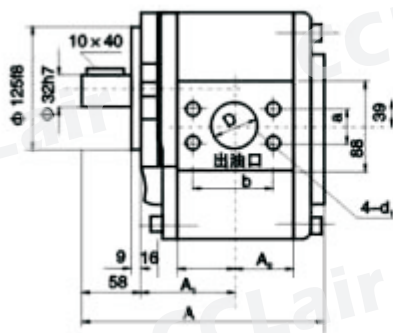

外形尺寸

CB-B450~550斜齿大排量型号规格

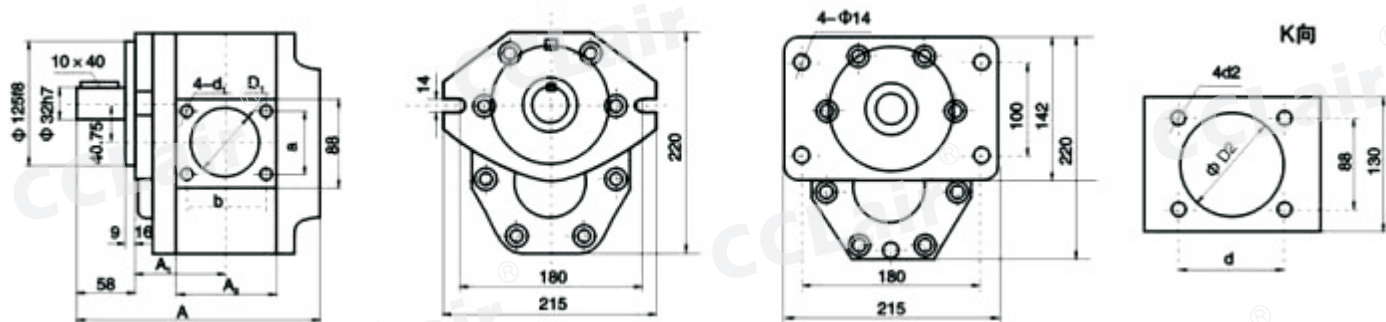

CB-B700斜齿大排量型号规格

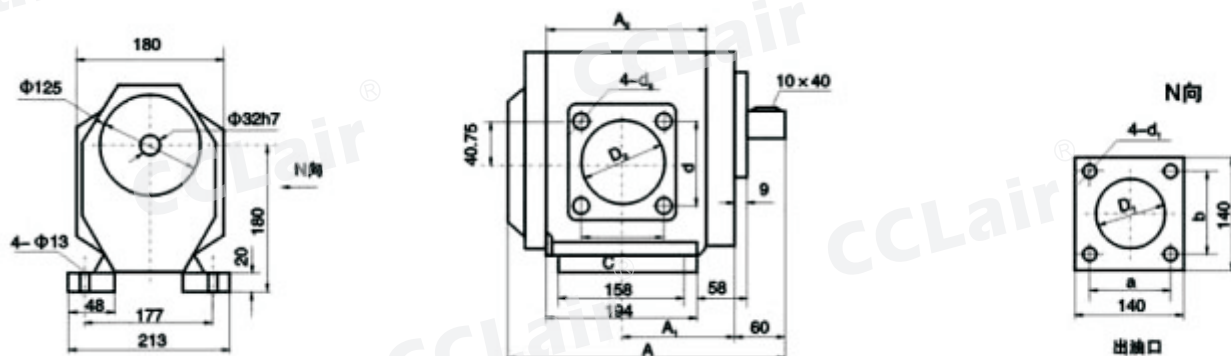

型号	A	A1	A2	出油口				吸油口			
				D1	a	b	d1	D2	C	d	d2
CB-B160	216	78.5	75	38	55	55	M12	48	55	55	M12
CB-B200	227	83.5	85	40	55	55	M12	50	55	55	M12
CB-B250	240	90.5	99	40	55	55	M12	50	55	55	M12
CB-B315	258	99.5	117	45	35.5	69.9	M12	55	42.9	77.8	M12
CB-B350	267	104	126	50	42.9	77.8	M12	63	50.8	88.9	M12
CB-B400	281	111	140	50	42.9	77.8	M12	75	70	110	M12
CB-B500	281	111	140	70	70	88	M12	100	88	100	M12
CB-B550	291	116	150	70	70	88	M12	100	88	100	M12
CB-B600	321	131	180	70	70	88	M12	100	88	100	M12
CB-B700	353	146	210	80	84.8	84.8	M12	110	106	106	M12
CB-B1000	376	149	140	75	96	96	M12	100	96	96	M12
CB-B1500	436	179	200	96	96	96	M12	125	120	120	M12