

TAC 系列空气过滤组合(三联件)

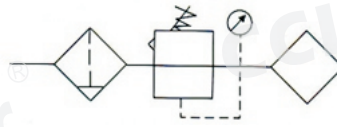

符号



订购码

TAC	2000	-	02	D
系列代号	壳体代号 1000 2000 3000 4000 5000		螺纹代号 M5:M5 02:1/4" 03:3/8" 04:1/2" 06:3/4" 10:1"	排水方式 空白:手动排水 A:差压排水 D:自动排水

技术参数

手动排水型	TAC1000-M5	TAC2000-02	TAC3000-02	TAC3000-03	TAC4000-04	TAC4000-06	TAC5000-06	TAC5000-10
自动排水型	TAC1000-M5D	TAC2000-02D	TAC3000-02D	TAC3000-03D	TAC4000-04D	TAC4000-06D	TAC5000-06D	TAC5000-10D
接管口径	M5×0.8	1/4	1/4	3/8	1/2	3/4	3/4	1
压力表口径	1/16	1/8	1/8	1/8	1/4	1/4	1/4	1/4
额定流量	90	500	2000	2000	4000	4500	5000	5000
环境及流体温度	5-60℃							
保证耐压力	1.5Mpa (15.3kgf/cm²)							
最高使用压力	1.0Mpa (10.2kgf/cm²)							
过滤孔径	5 um							
建议用油	透平1号油							
杯材料	聚碳酸酯							
杯护防罩	TAC1000~2000(无) TAC3000~5000(有)							
调压范围	TAC1000:0.05~0.7Mpa (0.51~7.1kgf/cm²)				TAC2000~5000:0.05~0.85Mpa (0.51~8.7kgf/cm²)			
阀型	带溢流型							
组件 过滤器	TAF1000	TAF2000	TAF3000	TAF3000	TAF4000	TAF4000	TAF5000	TAF5000
组件 减压阀	TAR1000	TAR2000	TAR3000	TAR3000	TAR4000	TAR4000	TAR5000	TAR5000
组件 油雾器	TAL1000	TAL2000	TAL3000	TAL3000	TAL4000	TAL4000	TAL5000	TAL5000
重量	0.26	0.74	1.18	1.18	2.14	2.47	3.82	3.82

外形尺寸

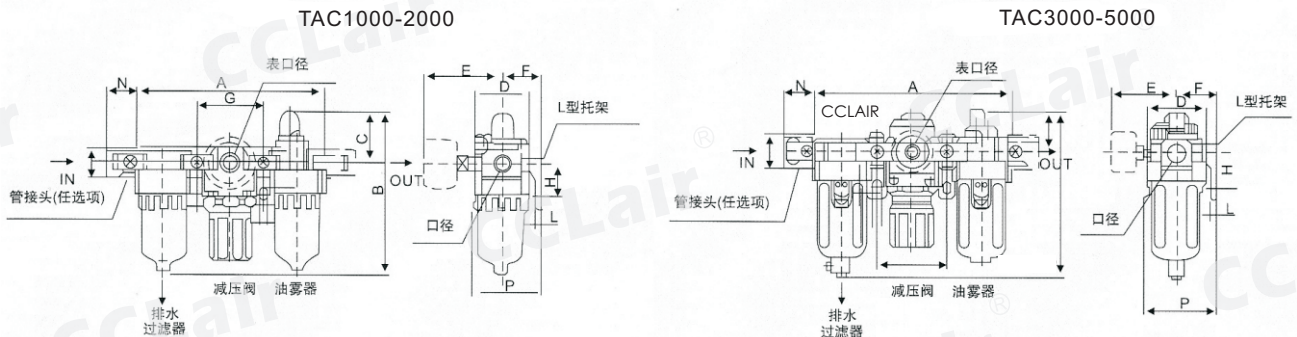

型号	口径	A	B	C	D	E	F	G	H	J	K	L	M	N	P	B
TAC1000	M5*0.8	91	84.5	25.5	25	26	25	33	20	4.5	7.5	5	17.5	16	38.5	105
TAC2000	1/4"	140	125	38	40	56.8	30	50	24	5.5	8.5	5	22	23	50	147.5
TAC3000	1/4",3/8"	181	156.5	38	53	60.8	41	64	85	7	11	7	34.2	26	70.5	194
TAC4000	3/8",1/2"	238	191.5	41	70	65.5	50	84	40	9	13	7	42.2	33	88	229
TAC4000-06	3/4"	253	193	40.5	70	69.5	50	89	40	9	13	7	46.2	36	88	230.5
TAC5000	3/4",1	300	271.5	48	90	75.5	70	105	50	12	16	10	55.2	40	115	309.5